

# XS-3 Parts

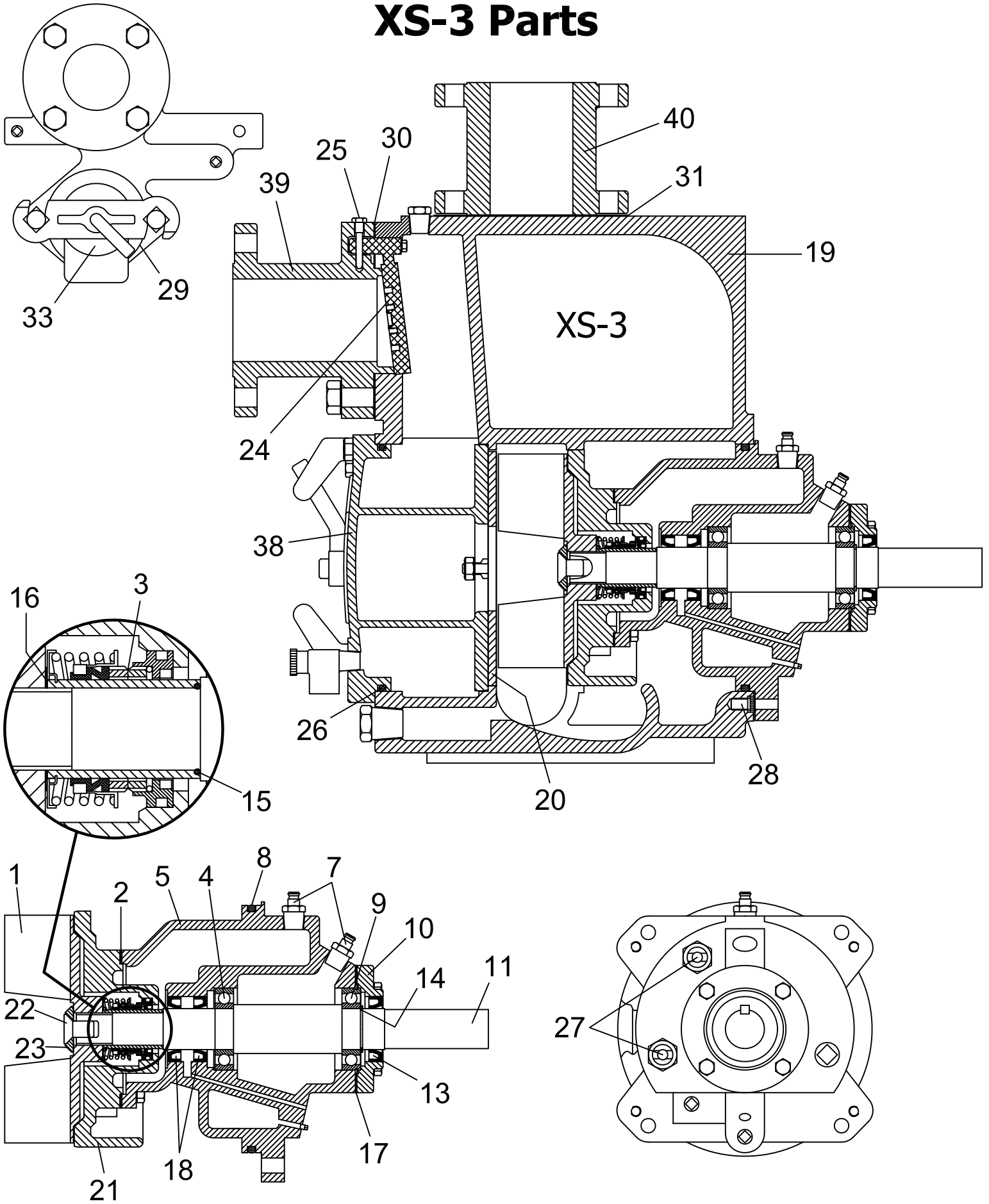

# XS-3 Parts



**ALL PRIME PUMPS**  
p. 800-803-0353

<i>item</i>	<i>description</i>	<i>AP part no.</i>	<i>GR part no.</i>
1*	impeller S3,XS3 - D/I(std)	311.010.100	11406-11010
1*	impeller S3,XS3 - CD4	311.010.104	11406-1718H
2*	gasket, seal plate S346, XS346, I34	311.010.200	10959G-20000
3*	seal, mech. - 1.5" (cart.w/sleeve) Δ	310.010.310	46513-151
3*	seal, mech. - 1.5" (comp.no-sleeve) ▲	310.010.300	12364A
4*	bearing, I/B - S2,S3,XS3	310.011.300	23252-013
5	housing, bearing, XS3 - C/I(std)	311.010.450	38251-410-10010
7	vent, air	310.010.600	S1530 w/bushing
8*	o-ring - Buna	311.011.600	S1748
8*	o-ring - Viton	311.011.601	25154-447
9*	bearing, O/B - S2,S3,XS3	310.012.300	S1749
10	cap, bearing, S2,S3,XS3 - C/I(std)	310.010.900	38322-219-10010
11	shaft XS3 - std (sleeve type) Δ	311.011.150	38514-563-16040
11	shaft XS3 - 17-4 (no-sleeve design) ▲	311.011.160	38514-564-1706H
13*	oil seal O/B - Nitrile	310.011.200	S1352
14	retaining ring, bearing	310.012.100	S244
15	o-ring - Buna	310.012.500	25152-022 (S2088)
15	o-ring - Viton	310.012.501	25154-022
16	shims, impeller	310.011.500	37J-17090
17*	gasket, bearing cap, S2,S3,XS3	311.012.000	38683-268-18000
18*	oil seal I/B - Nitrile	310.011.200	S1352
19	casing S3,XS3 - C/I(std)	311.030.000	11405B-10010
20*	wear plate S3,XS3 - std	311.210.000	11407A-15990
20*	wear plate S3,XS3 - CD4	311.210.004	11407A-1718H
21	seal plate S3,XS3 - C/I(std)	311.011.900	11837D-10010
21	seal plate S3,XS3 - CD4	311.011.804	11837D-1718H
22	screw, impeller - std	310.011.700	F1004S-1500G
22	screw, impeller - SS	310.011.701	F1004S-1704G
23	washer, impeller - std	310.011.800	31167-029-16000
23	washer, impeller - SS	310.011.801	31167-029-1706H
24*	check valve S3,XS3,I3 - STD	311.120.000	46411-060
24*	check valve S3,XS3,I3 - Viton	311.120.001	46411-100
25	pin, check valve S3,XS3	311.100.000	11557A-17010
26*	o-ring - Buna	311.011.600	S1748
26*	o-ring - Viton	311.011.601	25154-447
27	sight gauge	310.011.400	S1471
28	screw, rot.ass'y adj.	310.080.000	
29*	gasket, fill cover (all but S12)	310.280.000	50G-19210
30*	gasket, suction flg. S3,XS3	311.090.000	11412G-19370
31*	gasket, disch. flg. S3,XS3	311.040.000	25113-033
33	fill cover kit - std (bar,plate,gask,scrw)	310.350.000	
38	cover (clean-out) S3,XS3 - C/I(std)	311.130.000	42111-901
39	spool, suction S3,XS3 - C/I(std)	311.110.000	11412A-10010
40	spool, discharge S3,XS3 - C/I(std)	311.070.000	10845-10010

**Notes:**

- 1a. p/n 310.010.310 mechanical seal, cartridge - includes sleeve o-ring, impeller shim set & sleeve.
- 1b. p/n 310.010.300 mechanical seal, component - includes sleeve o-ring, impeller shim set & NO sleeve.
- 2. parts are FOB Jacksonville, FL
- 3. \* indicates recommended spares